



**GLOBAL MINING
P R O D U C T S**

Quality, Service, Value

Hydraulic Jacking Systems & Accessories





GLOBAL MINING PRODUCTS

Quality, Service, Value

Global Mining Products was founded by a group of individuals with years of experience in the heavy equipment industry who share a vision to provide quality products and services to the Mining, Oil and Gas, Logging, Trucking and Wind Industries at reasonable prices. Since the company's inception, Global Mining Products enjoys a worldwide reputation in providing a variety of top-quality products, trademark customer services and guaranteed best value.

At Global Mining Products, we are committed to delivering quality and value to our customers and partners by tailoring our products and specialized services to our customer's needs and priorities such as safety, productivity, cost savings and return on investment.

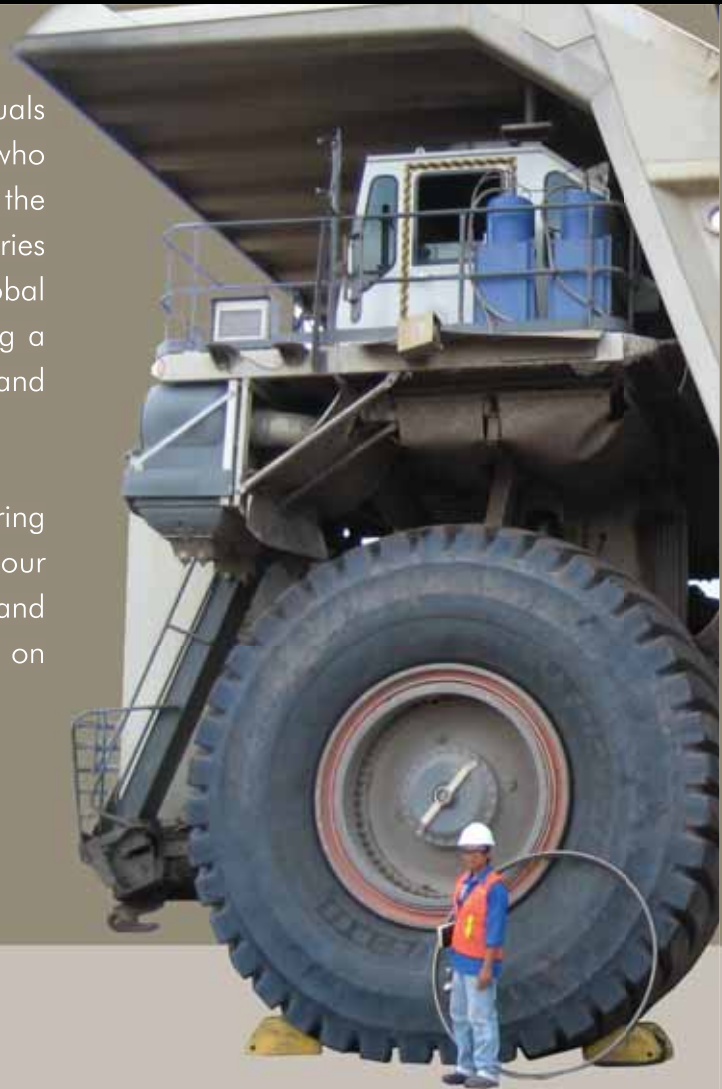

GLOBAL MINING PRODUCTS

Quality, Service, Value

HEAD OFFICE - CANADA

Global Mining Products Inc
105-19289 Langley ByPass
Surrey, B.C. V3S6K1
Ph: 604.576.2855
Fx: 604.576.2854
sales@globalminingproducts.com

USA

Global Mining Products Inc
2313 Last Chance Road
Elko NV 89801
Ph: 775.778.3410
Fx: 775.778.3418
elko@globalminingproducts.com

INDONESIA

PT GloMinPro Indonesia
Jl. Kol. Syarifuddin Yoes RT.75 No.04
Balikpapan 76115, East Kalimantan,
Ph: 6205.4287.4097
Fx: 6205.4287.4039
sales@glominpro.com



Table of Contents

Hydraulic Jacking Equipment

| | |
|----------------------------|----|
| Modular Jack System | 4 |
| BlackJack System | 6 |
| Jack Stands | 7 |
| Pump Carts | 7 |
| Component Handlers | 8 |
| Swivel Saddle | 8 |
| Bull Dog | 8 |
| Load Holding Rings | 9 |
| Extensions and Bases | 11 |



Modular Jack Systems

The RIGHT Jack for the RIGHT Job!

FEATURES:

- Air or Electric driven Hydraulic Pump Modules.
- 60, 100 and 175 Ton capacities.
- 13" thru 24" strokes. Custom strokes & retracted heights are available
- With Load Holdings Rings, the Lift Module mechanically supports up to 2½ times its rated capacity.
- Extensions are available to increase the effective retracted height of the Lift Module up to an additional 20".
- Swivel Saddle reduces the adverse effects of angled jacking surfaces up to 5°.
- Lift Module may be used in horizontal position to "push".



More Power and Productivity

- Featuring a manifold which allows you to operate 2 Lift Modules with a single pump.
- Once load is lifted, the pump may be disconnected & used in another application.



A single Pump Module can be used with multiple Lift Modules.

The Modular Jack System ensures you always have the right jack for the right job!

| Pump Module Required | Lift Module Part No. | Description | Retracted Height |
|--|----------------------|--------------------------------------|------------------|
| Air/Hydraulic Pump w/H60 p/n: JCK-PA60-H60 | JCK-L60-13 | 60 Ton 13" Stroke | 21" |
| | JCK-L60-16 | 60 Ton 16" Stroke | 25" |
| | JCK-L60-24 | 60 Ton 24" Stroke | 31" |
| Air/Hydraulic Pump w/H100 p/n: JCK-PA60-H100 | JCK-L100-16 | 100 Ton 16" Stroke | 27" |
| | JCK-L100-18 | 100 Ton 18" Stroke | 29" |
| | JCK-L100-24 | 100 Ton 24" Stroke | 33" |
| Air/Hydraulic Pump w/H175 p/n: JCK-PA60-H175 | JCK-L175-13 | 175 Ton 13" Stroke, w/ swivel saddle | 30" |
| Air/Hydraulic Pump w/H175 p/n: JCK-PA175-H175 | JCK-L175-15 | 175 Ton 15" Stroke, w/ swivel saddle | 32" |
| | JCK-L175-17 | 175 Ton 17" Stroke, w/ swivel saddle | 34" |
| | JCK-L175-24 | 175 Ton 24" Stroke, w/ swivel saddle | 41" |

NOTE: Pump Carts can be substituted for Power Modules

**** Additional Lifting Capacity Available upon request**

BlackJack Hydraulic Jacking System

- 60 & 100 Ton Capacity
- Balanced For Easy Maneuverability
- Pneumatic Tires
- Solid Steel Frame
- Aluminum Load Holding Rings & Extensions - Stored On Jack
- Easy Maintenance
- Unitized design situations where the versatility of a Modular Jack is not required
- Same proven design characteristics and components as the Modular Jack System
- With Load Holding Rings, can mechanically support up to 2.5 times its rated capacity
- Extensions available to increase the effective retracted height up to an additional 20"
- Optional Swivel Saddle reduces the adverse effects of angled surfaces up to 5°



| Part No. | Description | Retracted Height |
|-------------|-------------------------------|------------------|
| JCK-E60-13 | 60 Ton 13" Stroke [Electric] | 21" |
| JCK-A60-13 | 60 Ton 13" Stroke [Air] | 21" |
| JCK-E60-16 | 60 Ton 16" Stroke [Electric] | 25" |
| JCK-A60-16 | 60 Ton 16" Stroke [Air] | 25" |
| JCK-E100-16 | 100 Ton 16" Stroke [Electric] | 27" |
| JCK-A100-16 | 100 Ton 16" Stroke [Air] | 27" |
| JCK-E100-18 | 100 Ton 18" Stroke [Electric] | 29" |
| JCK-A100-18 | 100 Ton 18" Stroke [Air] | 29" |

**** Additional Lifting Capacity Available upon request**

Jack Stands



- 160,000 Lbs. capacity.
- 6" extension available for 37" height.
- Flip up wheels to prevent trip hazard.
- 10" x 10" replaceable rubber wear pad.
- Easy to position with removable handle.

| Part No. | Description |
|-------------|--|
| JS-M80-41 | Jack Stand 80 Ton |
| JS-M120-57 | Jack Stand Assembly 120 Ton - 57" Tall |
| JS-M120-24 | Jack Stand Assembly 120 Ton - 24" Tall |
| JS-M120-40 | Jack Stand Assembly 120 Ton - 40" Tall |
| JSE-M80-10 | Extension, Jack Stand - 10" |
| JSE-M120-6 | Extension 6" 120 Ton |
| JSE-M120-10 | Extension 10" 120 Ton |
| JSE-M120-12 | Extension 12" 120 Ton |

Pump Carts



- Cart provides a convenient way to transport and operate tools.
- Large built in storage racks to store jack accessories and hoses.
- Available with easy rolling standard wheels or in a rough terrain version with large, low rolling resistance tires.
- A versatile and convenient way to provide hydraulic power to "other" 10,000 psi tools (single or double acting tools)
- Custom racking and cabinets are available for unique applications.
- Very economical alternative to purchasing an additional unitized pump and lift module.

| Part No. | Description |
|--------------|--------------------------------|
| JCK-PCE90 | Pump Cart, Electric |
| JCK-PCA90 | Pump Cart, Air |
| JCK-PCA90-RT | Pump Cart, Air - Rough Terrain |



Component Handler [JCK-CH-5000]

Assists in the removal and installation of:

- Belly Pans
- Tanks
- Transmissions
- Pumps
- Differentials
- Crankcases

Features

- Large wheels provide easy maneuvering.
- Independent patented locking system for maximum safety
- Tow loops front and back
- Head tilt +/- 5° and traverse of 4"

| Part No. | Description |
|-----------|-----------------------|
| JCK-SS60 | Swivel Saddle 60 Ton |
| JCK-SS100 | Swivel Saddle 100 Ton |
| JCK-SS120 | Swivel Saddle 120 Ton |
| JCK-SS175 | Swivel Saddle 175 Ton |

****Mandatory with extensions.**

Swivel Saddle

Swivel Saddle will compensate for a sloped jacking point - up to 5°, to reduce side loading stress.



The Bulldog A Lift Module Transporter [JCK-BD]

SAFETY

The proper capacity and height Lift Modules can be easily positioned under 'difficult to access' jacking points

VERSATILITY

Maneuver 60, 100, 120 and 175 ton capacity Lift Modules

VALUE

With the Modular Jack System you require fewer jacks to cover all your lifting needs



| Part No. | Description |
|---------------|---|
| JCK-LHR60-2 | Load Holding Ring 60 Ton - 2" |
| JCK-LHR60-3 | Load Holding Ring 60 Ton - 3" |
| JCK-LHR60-5 | Load Holding Ring 60 Ton - 5" |
| JCK-LHR60-13 | LHR 6013 Set - (2) 2", (1) 3" & (1) 5" |
| JCK-LHR60-16 | LHR 6016 Set - (2) 2", (1) 3" & (2) 5" |
| JCK-LHR60-24 | LHR 6024 Set - (2) 2", (1) 3" & (3) 5" |
| JCK-LHR100-2 | Load Holding Ring 100 Ton - 2" |
| JCK-LHR100-3 | Load Holding Ring 100 Ton - 3" |
| JCK-LHR100-5 | Load Holding Ring 100 Ton - 5" |
| JCK-LHR100-16 | LHR 10016 Set - (2) 2", (1) 3" & (1) 5" |
| JCK-LHR100-18 | LHR 10018 Set - (2) 2", (1) 3" & (2) 5" |
| JCK-LHR100-24 | LHR 10024 Set - (2) 2", (1) 3" & (3) 5" |
| JCK-LHR175-5 | Load Holding Ring 175 Ton - 5" |
| JCK-LHR175-3 | Load Holding Ring 175 Ton - 3" |
| JCK-LHR175-2 | Load Holding Ring 175 Ton - 2" |
| JCK-LHR175-13 | LHR 17513 Set - (2) 2", (1) 3" & (1) 5" |
| JCK-LHR175-17 | LHR 17517 Set - (1) 2", (3) 3" & (1) 5" |
| JCK-LHR175-24 | LHR 17524 Set - (1) 2", (2) 3" & (3) 5" |



Load Holding Rings

- Provides mechanical support.
- Welded on handles
- Various heights for flexibility.
- Internal Bevel reduces spreading



Extension Adaptors & Load Holding Ring Features

Swivel Saddle will compensate for a sloped jacking point, up to 5°, to reduce side loading stress, mandatory with extensions

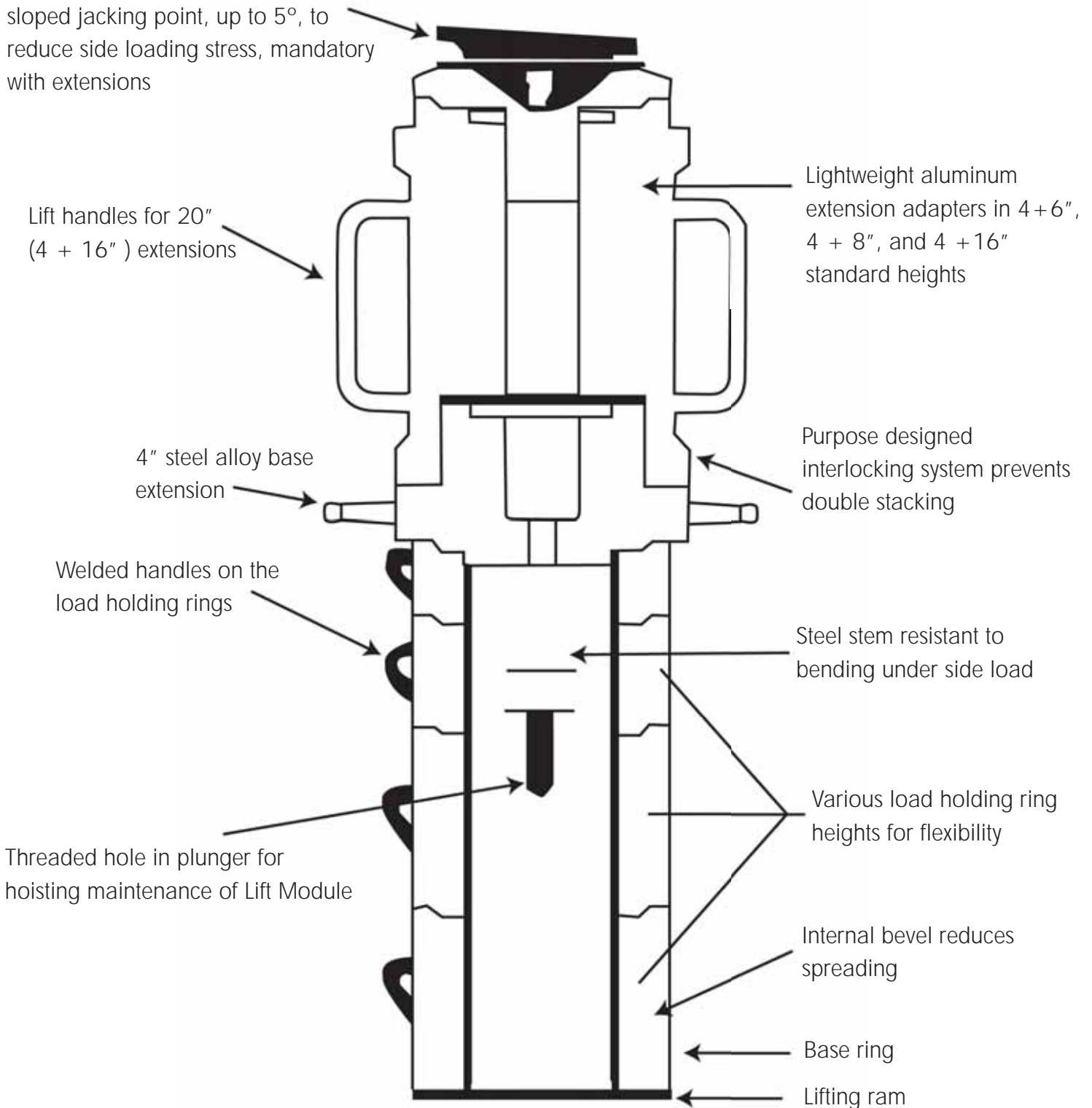



Extensions & Base

- Light weight aluminum extension adapters
- Available in 4+4", 4+8" 4+16" heights.
- Lifting handles for 20" (4+16") extensions.
- 4" Steel Alloy Base extension.
- Large diameter interlocking segments for added strength.

| Part No. | Description |
|--------------|---------------------------------|
| JCK-EXB60 | Extension, Steel Base 60 Ton |
| JCK-EX60-4 | Extension Adapter 60 Ton 4+4" |
| JCK-EX60-8 | Extension Adapter 60 Ton 4+8" |
| JCK-EX60-1 | Extension Adapter 60 Ton 4+16" |
| JCK-EXB100 | Extension, Steel Base 100 Ton |
| JCK-EX100-4 | Extension Adapter 100 Ton 4+4" |
| JCK-EX100-8 | Extension Adapter 100 Ton 4+8" |
| JCK-EX100-16 | Extension Adapter 100 Ton 4+16" |
| JCK-EXB120 | Extension, Steel Base 120 Ton |
| JCK-EX120-4 | Extension Adapter 120 Ton 4+4" |
| JCK-EX120-8 | Extension Adapter 120 Ton 4+8" |
| JCK-EX120-16 | Extension Adapter 120 Ton 4+16" |
| JCK-EXB175 | Extension, Steel Base 175 Ton |
| JCK-EX175-4 | Extension Adapter 175 Ton 4+4" |
| JCK-EX175-8 | Extension Adapter 175 Ton 4+8" |
| JCK-EX175-16 | Extension Adapter 175 Ton 4+16" |

****Steel base required for use with all extensions.**

Suspension Adapters

| Part No. | Description |
|-----------------|--|
| JCK-RSA120-830E | Rear Suspension Adapter K-830E (120 Ton Lift Module) |
| JCK-RSA175-830E | Rear Suspension Adapter K-830E (175 Ton Lift Module) |
| JCK-RSA175-930E | Rear Suspension Adapter K-930E (175 Ton Lift Module) |
| JCK-FSA100 | Front Suspension Adapter (100 Ton Lift Module) |
| JCK-FSA120/175 | Front Suspension Adapter (120/175 Ton Lift Module) |

